

# Portable Exchange Deionization Pressure Vessels

- ◆ Non-Code Construction
- ◆ 100 PSIG Working Pressure
- ◆ NFS/ANSI 61 Epoxy Lined
- ◆ Safety Blue Epoxy Exterior
- ◆ Galvanized Skid Base

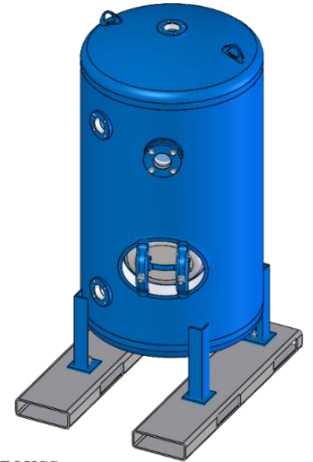
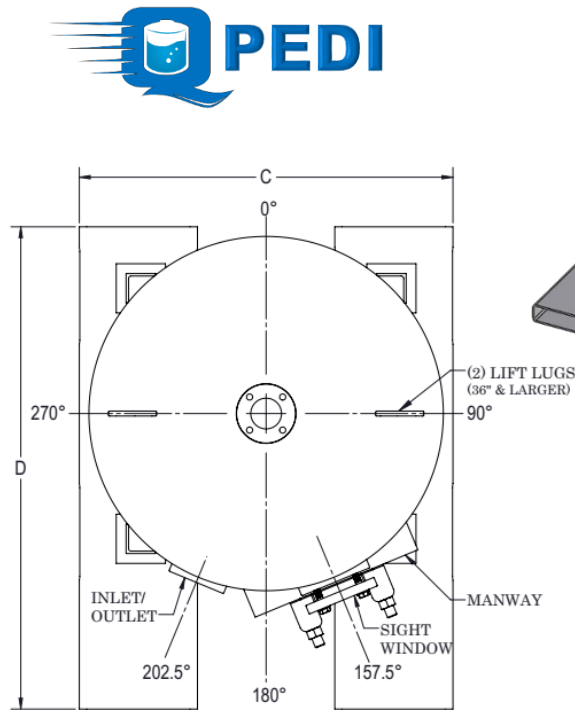
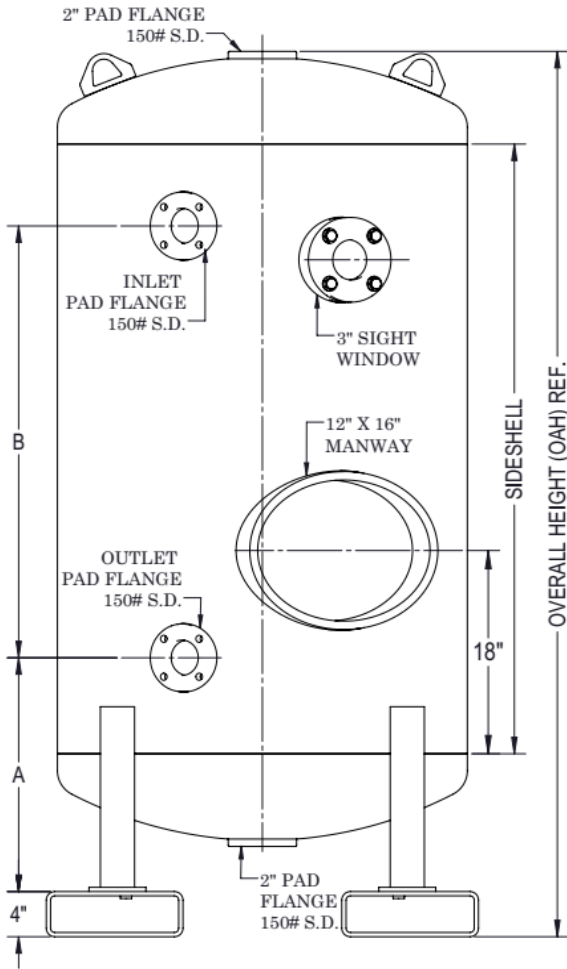

DESIGN/SPECIFICATIONS SUBJECT TO CHANGE WITHOUT NOTICE

## DIMENSIONAL CHART

DIA.	SIDE SHELL	INLET/OUTLET	A	B	C	D	OAH	VOLUME (CU. FT.)	MODEL #
24"	60"	2" PAD	14-3/16"	46-1/2"	28"	37"	76-1/8"	16.9	QPEDI2460
30"	57"	2" PAD	18-15/16"	41-1/4"	31"	43"	77-13/16"	26.6	QPEDI3057
30"	60"	2" PAD	18-15/16"	44"	31"	43"	80-9/16"	27.7	QPEDI3060
36"	54"	2" PAD	20-11/16"	38-1/4"	38"	49"	78-7/16"	37.1	QPEDI3654
36"	54"	3" PAD	20-11/16"	38-1/4"	38"	49"	78-7/16"	37.1	QPEDI3654-3
36"	60"	2" PAD	20-11/16"	44"	38"	49"	84-3/16"	40.4	QPEDI3660
36"	60"	3" PAD	20-11/16"	44"	38"	49"	84-3/16"	40.4	QPEDI3660-3
42"	52"	3" PAD	21-13/16"	36-1/4"	43"	55"	78-5/8"	50.1	QPEDI4252
42"	60"	3" PAD	21-13/16"	44"	43"	55"	86-3/8"	56.2	QPEDI4260
48"	48"	3" PAD	23-11/16"	32-1/4"	49"	61"	78-3/8"	63.5	QPEDI4848
48"	60"	3" PAD	23-11/16"	44"	49"	61"	90-1/8"	75.6	QPEDI4860