

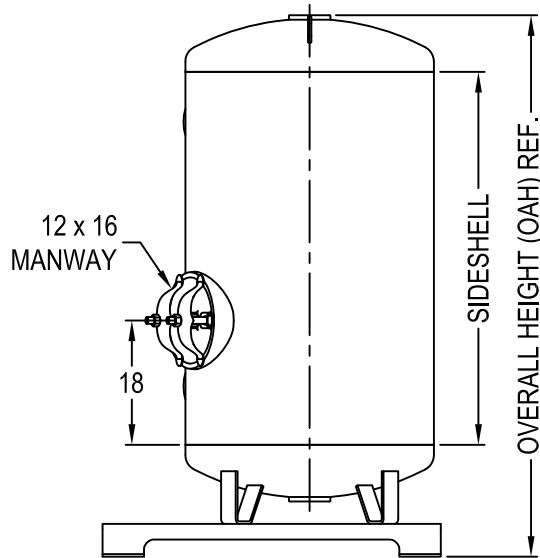

P.O.Box 338, Kendallville, IN 46755

Phone: 800-348-2514 | Fax: 800-348-1514 | Email: quote@quicktanks.com | Web: www.quicktanks.com

**NON-CODE QUICK PORTABLE EXCHANGE D.I. (QPEDI) TANKS  
VINYL ESTER LINED & FINISH COATED IN SAFETY BLUE EPOXY  
WITH GALVANIZED SKID BASE  
100 PSIG WORKING PRESSURE**

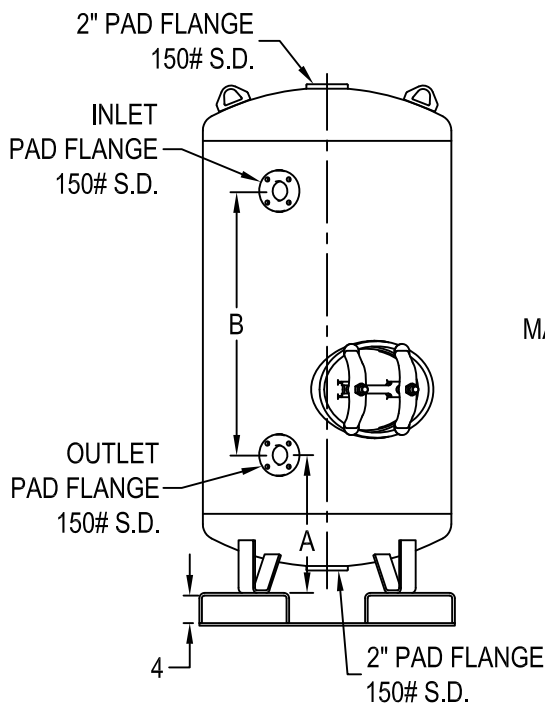
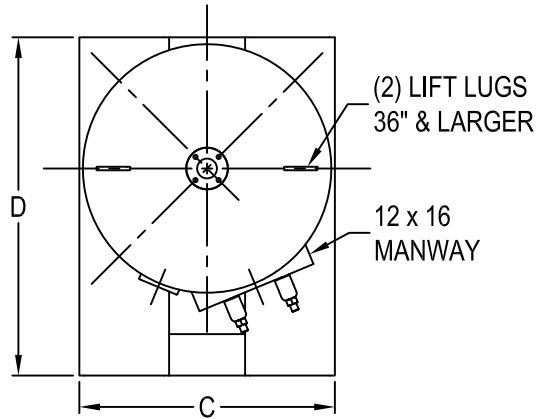

DIMENSIONAL CHART

DIA.	SIDE SHELL	INLET / OUTLET	A	B	C	D	OAH	VOLUME (US GAL.)	HEAD VOLUME INCL. SF (cu. ft.)	MODEL #
24"	60"	2" PAD	14"	46.5"	28"	37"	77"	127	0.6	QPEDI2460
30"	57"	2" PAD	18"	41.25"	31"	43"	79"	194	1.9	QPEDI3060
36"	54"	2" PAD	20"	38.25"	37"	49"	79"	278	3.0	QPEDI3660
42"	52"	3" PAD	21"	36.25"	43"	55"	79"	375	4.6	QPEDI4260
48"	48"	3" PAD	23"	32.25"	49"	61"	79"	475	7.0	QPEDI4860